

A Site Manager's Guide to New Water Mains and Service Connections on New Developments

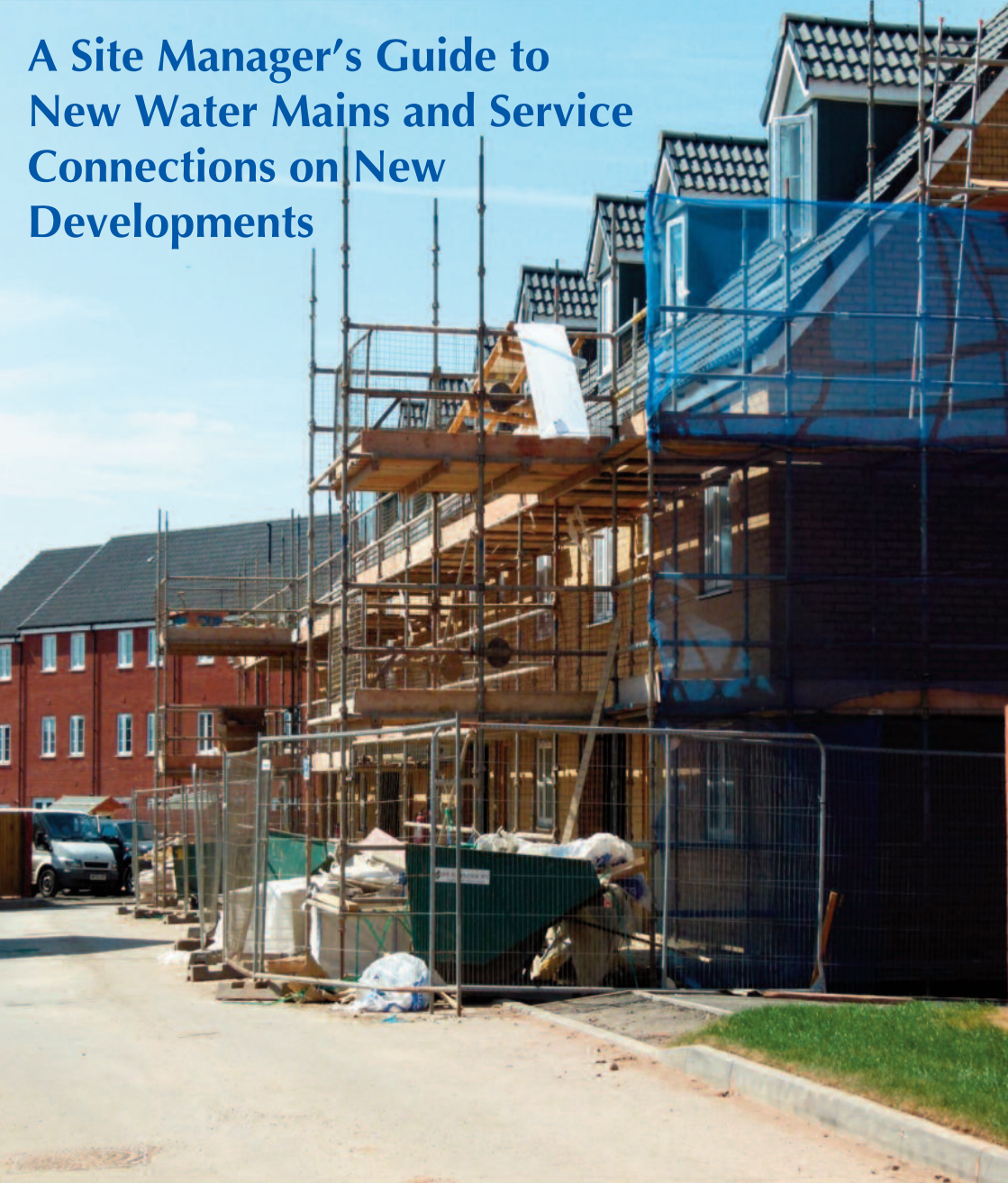

Overview

This site manager's guide provides information on health and safety, new water mains, new service connections and property occupancy on new developments. This guide is intended to assist suitably trained and competent site managers in order that they are better able to obtain the services they require in a reliable and cost-effective manner.

This guide is not intended to replace the terms and conditions of application/agreement and users of this guide should always refer to all documentation provided throughout the application process and that of national regulations/requirements.



Table of contents

	Page
Health and safety	1
Water mains	1
Pre-commencement meeting	2
Site preparation and commencement of main laying	3-4
Post-construction sign off	5
Use of hydrants	5
Fire hydrants on new water mains	6
Service connections	7
Specification for underground services	7-11
Occupancy of new properties	12



Health and safety

Any design and construction work must comply with CDM Regulations 2015. If in doubt please refer to the HSE website.



Water mains - key points

- Hold pre-commencement meeting with a South West Water representative prior to any new mains work starting.
- The line of the main is clear from obstructions, the roads and footways are clearly marked, and the line and levels are clearly defined, prior and during works
- Ensure fire hydrants and other street furniture is accessible and free from obstructions and damage
- Barrier pipes must be used on contaminated land.

Pre-commencement meeting

Before the construction of the new water main commences a South West Water representative will arrange a pre-commencement site meeting. This meeting should be attended by a South West Water representative and a representative from the developer and if appropriate a representative from the self-lay organisation. At the meeting the following will be discussed and agreed and minutes **must** be taken and issued to all attendees.

- A provisional commencement date to start the mains construction
- That the kerb line and levels will be available by the construction start date
- Provision of a designated contamination-free area for the storage of pipes and fittings so that delivery can be arranged (off ground storage required)
- Exchange health and safety and CDM information
- Comparison between the lengths of mains to be constructed to the mains design drawing
- That the plot numbering and plot layouts haven't changed or been amended since the drawing up of the mains design drawing
- To be sure the line and level of other utilities' services in the vicinity of the water mains or service pipes have been identified
- Service connection types (boundary box, manifolds etc) and confirmation of boundary box positions
- Contact details relating to the particular scheme
- Testing and commissioning to relevant timescales
- Any other site-specific information.

Important note: If the South West Water representative arrives on site and the agreed construction phase cannot be completed due to reasons within the developer's control, South West Water reserves the right to charge remobilisation to site and any additional connections required as a result of the agreed construction phase not being completed.

Site preparation and commencement of main laying

Before construction of the new main starts it is important that:

- The proposed line and level of the main is clear and free from obstructions
- A kerb race or other permanent identification of the limits of the roads or footpaths is in place (South West Water will not accept liability for kerbs that are damaged during the water main installation or commissioning)
- The line and level to the back edge of the footpaths are clearly defined.

South West Water will lay new water mains in accordance with the National Joint Utilities Group (NJUG) - Guidelines on the Positioning and Colour Coding of Underground Utilities Apparatus - Volume 1 and expects developers to ensure that other utilities also lay their apparatus in accordance with the NJUG guidelines. The reason for this is to safeguard the health and safety of our staff and to ensure that our apparatus remains accessible for future maintenance. Please refer to the diagram below.

All people working for South West Water and its contractor must be given a site induction by the developer immediately upon arrival on site. They will also be required to sign in and out at the site office each day they are on site.

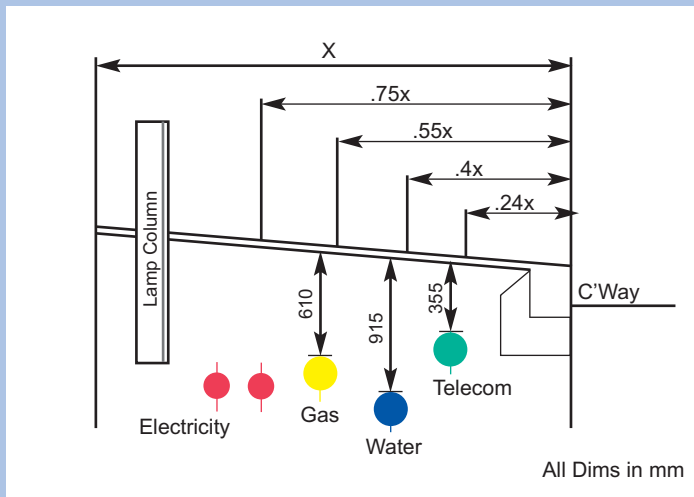

If South West Water apparatus is obstructed by other utility apparatus laid subsequent to our own main laying or by other obstructions eg scaffolding etc we reserve the right to suspend the individual service connections until the correct access is provided. In these instances the developer will incur an abortive charge per connection (see current charges scheme for details) and the connections will be delayed.

Service pipe road crossing ducts should be blue in colour and installed by the developer in the positions shown on the design drawing. They should be a minimum of 50mm diameter and at a depth of 750mm – 1350mm below the finished service level. The position of the ducts should be clearly marked. No mains to be installed in ducts and a maximum of five service pipes per duct.

The developer will be responsible for ensuring that all chambers, where installed, are vertical, and frames and covers are mortared to the chamber sections at the correct level to meet the finished surface levels. Any identified damage to the water mains and associated fittings will be repaired by the water company and recharged to the responsible party.

To enable future maintenance, a minimum clearance of 300mm will apply to distribution mains and must be maintained where any works or services are installed adjacent to a water main. The developer will be recharged for any diversionary works where this cannot be achieved. Specific advice will be given for trunk mains.



District heating

The proximity of district heating apparatus may affect the efficiency and operation of our underground apparatus. Therefore before district heating apparatus is laid, contact must be made with South West Water.

Installers of district heating must consider the location, spacing and depth of cover to avoid potential conflict with our existing and proposed underground apparatus.

Post-construction sign-off

Once the new water main is commissioned, South West Water or its contractor will walk the line of the new main to ensure that:

- Fittings have been installed as per the design drawing
- Fittings are in chambers set to finish levels given
- Correct covers are fitted to the fittings
- Correct marker posts are installed.

Any defects identified at this point will be rectified by South West Water and recharged accordingly. Once the site is signed off as complete and there are no outstanding defects, any subsequent damage to the main or mains fittings will be recharged to the responsible party.

Use of hydrants

Unauthorised use of a hydrant is an offence under Section 174 of the Water Industry Act 1991. In order to avoid the risk of legal proceedings, please contact South West Water to get authorisation to use a designated hydrant and to hire a metered standpipe. Interference with hydrants can result in:

- Contamination of the water network
- Damage to fire hydrants
- Discolouration of the water network
- Burst mains due to pressure surges
- Reduction in pressure of the water network
- Interruption to supply to surrounding properties.



Fire hydrants should not be used for temporary building water supplies.

Fire hydrants on new water mains

When designing new water mains South West Water will liaise with the fire authorities regarding the provision of fire hydrants, and will install new fire hydrants where requested by the fire authority.

Fire hydrants are life-saving devices so it is important that once the new water main is commissioned:

- Site access is made available to fire service personnel so that the new fire hydrants can be inspected and adopted by the fire authority



- The new fire hydrants are kept free and are not covered or obstructed as they must be accessible in the event of a fire during the construction of the development
- When constructing footpaths and other final surfaces, the correct fire hydrant cover is installed, the fire hydrant marker post is in position, and the fire hydrant cover is to finished surface level and not buried
- Fire hydrant chambers are free of debris and surfacing materials and the cover can be removed.

Service connections key points

- All service pipes to be installed to comply with Water Supply (Water Fittings) Regulations 1999
- Service pipes to be installed a minimum of 750mm deep and a maximum of 1350mm deep
- Meter face to be installed to a minimum 150mm deep and a maximum of 500mm. The depth from box inlet and outlet to finished surface shall be 750mm.
- All internal manifolds to be installed to South West Water's installation guidance prior to being connected
- Where site status is contaminated appropriate pipe systems must be installed as agreed with the water company e.g. barrier pipe
- Service pipes are capped and labelled to show which plot they supply (Watertight stop end, not tape or plastic bag).
- Ensure area is safe and clear from obstructions before requesting connections
- Inform South West Water of all occupants' details and date of occupancy .

Specification for underground services

It is the developer's responsibility to lay the service pipes from the property to the indicated point of connection. The installed service pipe and fittings must comply with Water Supply (Water Fittings) Regulations 1999. All materials used in meeting this responsibility are to be suitably approved, for example WRAS-approved for use on potable water supplies.

Service pipes must be a minimum of 750mm deep and no more than 1350mm. The pipe must be ducted where they enter the building so that the pipe can be easily retracted and replaced. An internal stop tap must be installed prior to service connections being made, and the end of the pipe connected to the main must be sealed. Service pipes are to be bedded and covered in sand prior to trenches being backfilled.

Service pipes should be laid in straight runs and should not cross neighbouring plots. Service pipes should not run down the public footpath or highway.

It is important that all service pipes are clearly marked or labelled as to which plot they serve before the connections are requested. Failure to label the service pipes may lead to delays or service connections being aborted.

Position of boundary boxes

Boundary boxes must be installed as agreed. Where we have installed the boundary boxes as instructed, any repositioning will be carried out at the developer’s cost.

It is important that the developer agrees the boundary box positions at the pre-commencement meeting.

Water regulations and approved contractors

All external service pipes and internal plumbing must comply with the Water Supply (Water Fittings) Regulations 1999. Self certification by approved plumbers or ground workers may negate the need for inspection. South West Water has the right to carry out water regulations inspections to ensure compliance. The water regulations are designed to prevent inefficient use of water, waste, misuse, undue consumption, or erroneous measurement of it, and most importantly to prevent contamination of drinking water.

Water services in contaminated ground

If the site has been deemed to be contaminated, the service pipes installed by the developer must be in either WRAS approved barrier pipe (Egeplast preferred) or plastic coated underground copper to BS EN 1057/1996

	Pipeline	Service Pipe	Meter Box
Standard	Polyethylene	Polyethylene	Standard boundary box
Contaminated land	Protected ductile iron or barrier pipe	Copper with polyethylene coating or WRAS approved barrier pipe	Boundary box for contaminated land

Internal manifold connections for blocks of apartments or flats

If any of the service connections on site are to be made using four or six way manifolds, the manifolds must be installed by your contractor before the connection(s) can be requested. Individual meters will be installed as required following the connection.

Temporary building/welfare supplies

Temporary building supplies can be made to either a temporary standpipe or to temporary site welfare facilities. All standpipes and welfare facilities must comply with the Water Supply (Water Fittings) Regulations 1999. Temporary supplies are not expected to be in place for more than 12 months and only one per site. When the temporary building supply is no longer required, South West Water must be contacted to arrange for the supply to be disconnected. All standpipes and/or taps that a hose may be connected to must be fitted with a double check valve.

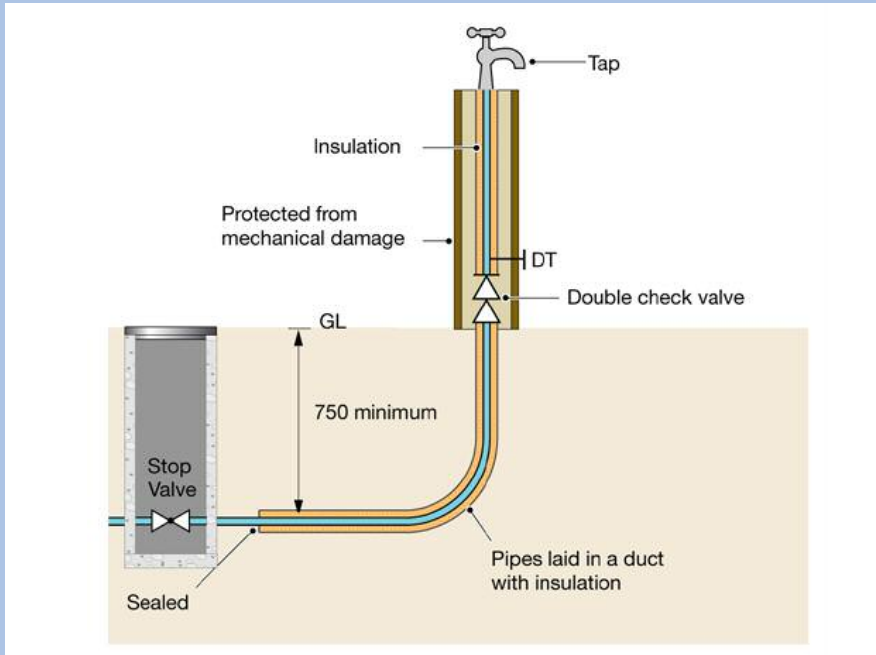

Temporary connection to permanent connection

The connection is initially used as a building supply but will be utilised as a permanent supply once the property is completed. During construction you will need to decide on the meter position from the options available. You should contact South West Water at the earliest opportunity when you want to convert the temporary supply to the permanent supply. All pipe work should be protected from both mechanical and frost damage.

Requesting domestic service connections

When the developer or developer's representative contacts South West Water to request service connections, they should make sure:

- Payment for the services has been made
- Property is secure (ie walls, doors, window and roof)
- The service pipe from the property to the connection point is in place and complies with the specification above and the Water Supply (Water Fittings) Regulations 1999
- The service pipe is clearly marked as to which property it supplies and is sealed to avoid contamination
- The area around the service connection is free from obstacles such as skips, scaffold and building materials
- The pipe inside the building has a stop tap fitted
- The ends of any ducts are exposed and marked
- The finished kerb line and levels are known
- The water main has been tested and commissioned before service connections are requested
- Boundary boxes are not be in driveways or on vehicle crossovers

You will be advised in advance of any additional conditions which may be required, for example non-domestic supplies will be inspected before connection can be made.

Deviation from any of the above may result in your connection(s) being aborted. If so this will incur a rebooking delay and abortive charges.

Chlorination of service pipes

If the service pipe you are installing is greater than 50mm internal diameter (63mm OD) and/or greater than 50m in length you will need to arrange for this to be chlorinated, tested and approved by South West Water before we will connect it to our network. We require a copy of your chlorination certificate and analysis results in order to authorise the connection(s). If there is any suspicion of contamination for any other reason, for example sewage or ground water, then chlorination and testing will be required. This is to ensure consumers and our infrastructure are not at risk of contamination.

New mains

All pipes and fittings for new mains should be transported and stored so as to prevent ingress or contamination. They should not be stored in direct contact with the ground and open ends should be capped or otherwise protected. Reasonable measures should be taken to exclude ingress or contamination during laying.

The pipe end should be capped whenever work stops for an extended period (e.g. overnight). Before a new main is brought into service it must be cleaned, pressure tested and disinfected.

Water samples must be taken and analysed and satisfactory results obtained in respect of microbiological and aesthetic parameters before connections to the existing network are undertaken. Sampling and analytical testing requires at least four to five days by an approved laboratory.

Post-connection damage

Any damage caused to boundary meter boxes or manifolds after they have been connected will be repaired or replaced by South West Water and the full cost of the work will be recovered from the responsible party.

Occupancy of new properties

The developer could be charged for any standing charges and water consumption until South West Water is informed of the new occupant's details.

When notifying South West Water of a new occupant the following information will be required:

- Property reference number (the property reference number can be found on the builder's card which is sent out when the new account is set up)
- Full name(s) of occupant (responsible for bill)
- Full postal address of property
- Date of occupancy
- Occupier's previous address
- Meter serial number and reading.

Useful contact numbers

South West Water - Services Helpline
0344 346 2020* 8am-6pm Mon-Fri, Emergencies only at any other time.

New Connections
0800 083 1821

Please note you will need to state your work request number when contacting South West Water. You will have separate work request numbers for the mains scheme and service connections.

*03 numbers are charged at standard rates and will be included in any free minutes in a mobile or landline phone contract.